

J. BROOKS.

Machines for Turning Sewing-Machine Needle-Blanks.

No. 135,767.

Fig. 1.

Patented Feb. 11, 1873.

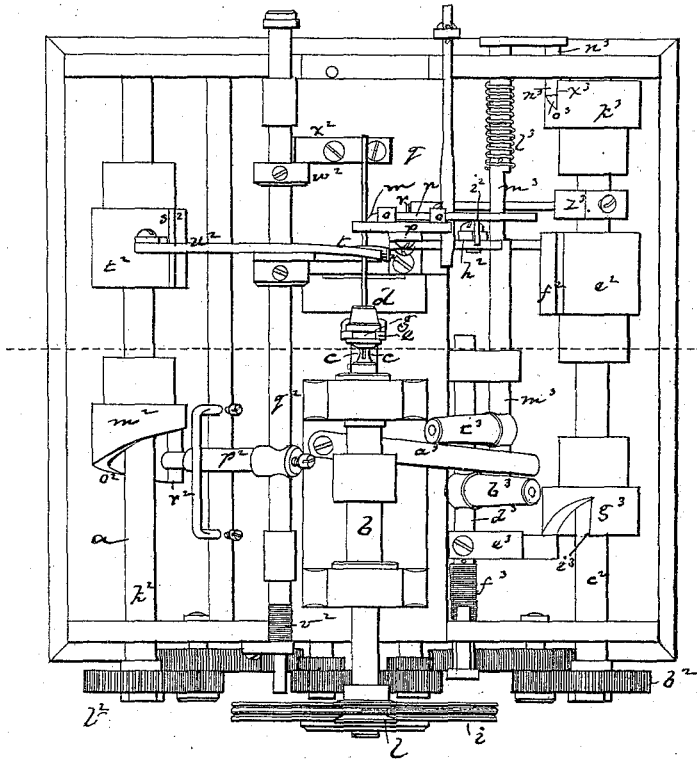
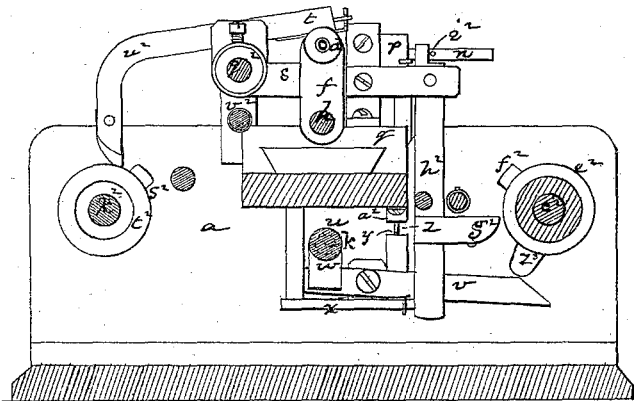

Fig. 3.



Witnesses.  
M. W. Frothingham,  
L. H. Ratimer.

Inventor.  
John Brooks,  
By his Attorneys,  
Cross & Gould

J. BROOKS.

Machines for Turning Sewing-Machine Needle-Blanks.

No. 135,767.

Patented Feb. 11, 1873.

Fig. 2.

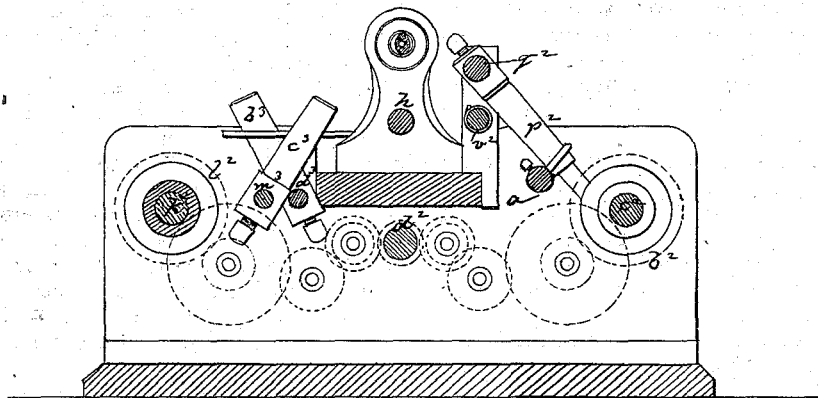

Witnesses.  
No. W. Frothingham.  
L. H. Latimer.

Inventor.  
John Brooks.  
By his Atty.  
Crosby & Gould

# UNITED STATES PATENT OFFICE.

JOHN BROOKS, OF NORTH BRIDGEWATER, MASSACHUSETTS, ASSIGNOR TO HIMSELF AND CHARLES HOWARD & CO., OF SAME PLACE.

## IMPROVEMENT IN MACHINES FOR TURNING SEWING-MACHINE-NEEDLE BLANKS.

Specification forming part of Letters Patent No. 135,767, dated February 11, 1873.

*To all whom it may concern:*

Be it known that I, JOHN BROOKS, of North Bridgewater, in the county of Plymouth and State of Massachusetts, have invented an Improvement in Machines for Turning Sewing-Machine-Needle Blanks, &c.; and I do hereby declare that the following, taken in connection with the drawing which accompanies and forms a part of this specification, is a description of my invention sufficient to enable those skilled in the art to practice it.

The invention relates to details of construction and arrangement of mechanism for turning the blanks for sewing-machine needles, and particularly to an arrangement of the wire-gripping, feeding, and reducing devices, by which their successive operations are automatic.

The drawing represents a mechanism or machine embodying my invention.

Figure 1 shows a plan of the machine. Fig. 2 is a vertical cross-section on the line  $x x$ , looking toward the driving-wheel. Fig. 3 is a section on the same line, but looking in the opposite direction.

$a$  denotes the frame of the machine.  $b$  is the tubular spindle or arbor through which the wire extends, and at the outer end of which are jaws by which the wire is gripped by the action of a suitable chuck, so as to be held and rotated by the spindle to present it to the action of the cutter.  $c c$  denote the jaws at the end of the spindle;  $d$ , the rotary chuck that, by movement over said jaws, presses them upon the wire to gripe it—a fork,  $e$ , at the top of an arm,  $f$ , entering a groove,  $g$ , extending around the chuck to move the chuck to and from the gripping end of the spindle. This arm extends from a slide-rod,  $h$ , sliding in the head-stock. The spindle  $b$  is driven from a pulley,  $i$ , on the driving-shaft  $k$ , said pulley being belted to a pulley,  $l$ , on said shaft.  $m$  denotes the cutter at the end of a shank,  $n$ , sliding in bearings  $o$  on the face of a plate,  $p$ , fixed to or with respect to the lathe-slide or tail-stock  $q$ . The cutter-shank is pressed forward to act upon the wire by a suitable spring,  $r$ , and is carried out of action when the needle-length of wire is turned, as will presently be described.  $s$  denotes a stationary jaw, and  $t$  a movable jaw, between and by which the wire

is gripped to feed it forward after the cutter has turned the length of one needle-blank and prior to its action to turn the next length, the jaws sliding back without pressure upon the wire, but being caused to gripe the wire and carry it forward with them. The driving-shaft being rotated to turn the wire and present it to the action of the turning-tool, the slide  $q$  is slid back to carry the cutter along a needle-shank length in action upon the wire, during which action the wire-feeding jaws are slid back to position to again gripe the wire; the cutter is then released; the chuck is started forward to cause the gripping-jaws of the spindle to release their gripe upon the wire; the wire-feeding jaws then again gripe the wire and carry it forward; the chuck is then again thrown over the spindle-jaws to cause them to gripe the wire; the wire-feed jaws release the wire, and the cutter is again thrown forward against the wire—all these movements being produced automatically and by the continuous rotating movement of the driving-shaft, as follows: The spindle is rotated to rotate the wire, as before described, and on the driving-shaft is a feed-screw,  $u$ , under which is a half-nut,  $v$ , on the end of a lever,  $w$ , which lever is pivoted to a tail-piece,  $x$ , extending down from the slide or carriage  $q$ . The front arm of the lever, being pressed down, holds the half-nut in contact with the feed-screw, and, as the screw rotates, the carriage and cutter move forward. During this forward movement, the lever  $w$  is held in position by a shoulder,  $y$ , of a spring-latch,  $z$ , and when the cutter has reduced the wire to the desired length the upper end of the latch  $z$  strikes a projection,  $a^2$ , and throws the shoulder of the latch off of the lever, the outer arm of the lever being then thrown up by a suitable spring, thereby throwing down the half-nut and arresting further movement of the slide and cutter by the screw. The cutter is thrown back at the same time, as follows: By a train of gearing the gear-wheel  $b^2$  of a shaft,  $c^2$ , is connected with a pinion,  $d^2$ , on the driving-shaft. On this shaft is a collar,  $e^2$ , carrying a projecting shoulder-piece,  $f^2$ , and at the same time the latch  $z$  strikes the projection  $a^2$  the shoulder  $f^2$  strikes an arm,  $g^2$ , extending from a vertical lever,  $h^2$ , the upper arm of which strikes against a pin,

$i^2$ , projecting from the cutter-shank  $n$ , throwing back said shank and withdrawing the cutter from contact with the wire. While the slide and cutter have been sliding back, (for the action of the cutter upon the wire,) the wire-feed jaws have been moving back, their back movement being produced at first by the slide  $q$ , and then from a shaft,  $k^2$ , a gear,  $l^2$ , upon which is connected by a gear-train with the pinion  $d^2$  on the driving-shaft. This shaft  $k^2$  carries a cam-cylinder,  $m^2$ , having a cam,  $o^2$ , on its end, which cam, as the shaft  $k^2$  rotates, strikes an arm,  $p^2$ , extending from the slide-rod  $q^2$  which carries the wire-feed jaws, thereby moving back the rod and the jaws until the shoulder  $r^2$  of the cam passes the arm  $p^2$ , the rod being then free to slid forward. At the instant the cam-shoulder passes the arm, a shoulder,  $s^2$ , on a cylinder,  $t^2$ , on said shaft  $k^2$ , strikes a tail-piece,  $v^2$ , of the movable jaw  $t$ , throwing down said jaw and causing it to gripe the wire between it and the fixed jaw  $s$ ; and the slide-rod and jaws, with the wire griped between the jaws, will then be thrown forward by the stress of a suitable spring,  $v^2$ , the rod being arrested by an adjustable collar,  $w^2$ , fastened upon the rod, striking a stop,  $x^2$ , on the slide  $q$ .

Before the feed-jaws can move the wire forward, the gripe of the tubular spindle-jaws upon the wire must be released, and this is effected as follows: Through the slide-rod  $h$  that carries the chuck  $d$  a lever-arm  $a^3$  extends, the inner end of the arm being pivoted to the head-stock, and the other end of the arm extending between two pins or arms,  $b^3$   $c^3$ . The arm  $b^3$  extends from a slide,  $d^3$ , that carries an arm,  $e^3$ , which, by the stress of a suitable spring,  $f^3$ , is held against or toward the end and cam-surface of a cam-cylinder,  $g^3$ , on the shaft  $c^2$ . Before the cutter begins to act, the cam  $g^3$  forces the arm  $b^3$  back from the lever-arm  $a^3$ , and the end of the cam-cylinder, as it rotates, holds the arm back until the feed-jaws gripe or are about to gripe the wire, and then the cam-shoulder  $i^3$  passes the arm  $e^3$ , leaving the arm  $b^3$  free to be thrown against the lever-arm  $a^3$  by the stress of the spring  $f^3$ , the chuck-slide being thrown forward by the lever, thereby releasing the gripe of the spin-

dle-jaws from the wire. While the arm  $b^3$  is held in contact with the lever-arm to release the wire from the spindle, the other arm  $c^3$  is held out of contact with the lever-arm by the end of a cam-cylinder,  $k^3$ , on the shaft  $c^2$ , the slide  $m^3$  upon which said arm is fixed, being pressed back by a spring,  $l^3$ , and having an arm from which a pin,  $n^3$ , extends into contact with the end of the cam-cylinder. The cam-face  $o^3$  of the cylinder presses forward the slide just after the spring  $l^3$  has thrown it back to move the lever-arm, and the end of the cylinder then holds the arm  $c^3$  out of contact with the lever-arm  $a^3$  until the feed-jaws have fed forward the wire, and the arm  $b^3$  that throws out the chuck and releases the gripe of the spindle-jaws has been thrown back. Then the cam-shoulder  $x^3$  passes the pin  $n^3$ , and the arm  $c^3$  is thrown against the lever-arm  $a^3$ , causing it to throw the chuck upon the spindle-jaws to gripe the wire. At the same time the wire is thus griped the shoulder  $y^2$  passes the lever  $h^2$  and the spring  $r$  throws forward the cutter, and an arm,  $z^3$ , on the shaft  $c^2$ , throws down the outer arm of the lever  $v$  and causes it to be caught by the shoulder of the spring-latch  $z$ , the movement of the lever again carrying the feed-nut into connection with the feed-screw. Another needle-length of the wire will then be reduced as before.

By suitable adjustments, the needle-blanks may be turned to any requisite length and diameter.

By the machine thus organized, continuous wire entering the machine is automatically turned for forming the blanks of successive needles, without other attention on the part of the attendant than to introduce the wire.

I claim—

The combination and arrangement of the mechanism, operating substantially as described, to successively and automatically reduce the wire to form the needle-blanks.

Executed this 6th day of November, A. D. 1872.

JOHN BROOKS.

Witnesses:

CHAS. HOWARD, Jr.,  
H. HERBERT HOWARD.